

Imprinting System for Flexible Packaging Film, Labels and Cartons

High speed imprinting system designed for all intermittent and continuous motion packaging machines. The US-5000 can produce up to 180 imprints per minute on all film, labels, foil and chipboard boxes. Utilizing rubber type and a unique disposable inking system, this unit provides the highest quality codes available while substantially reducing operating costs.

Will Print

- Price / Date Codes
Exp. Dates / Lot. #'s
- Instructions i.e.;
"Peel to Open"
Shift Codes
Production Dates

Features

- No heat required
- Rubber Type
- Totally air driven
- Independent Drive Motor
- Disposable ink cartridge
- Adjustable ink system
- Narrow, compact design

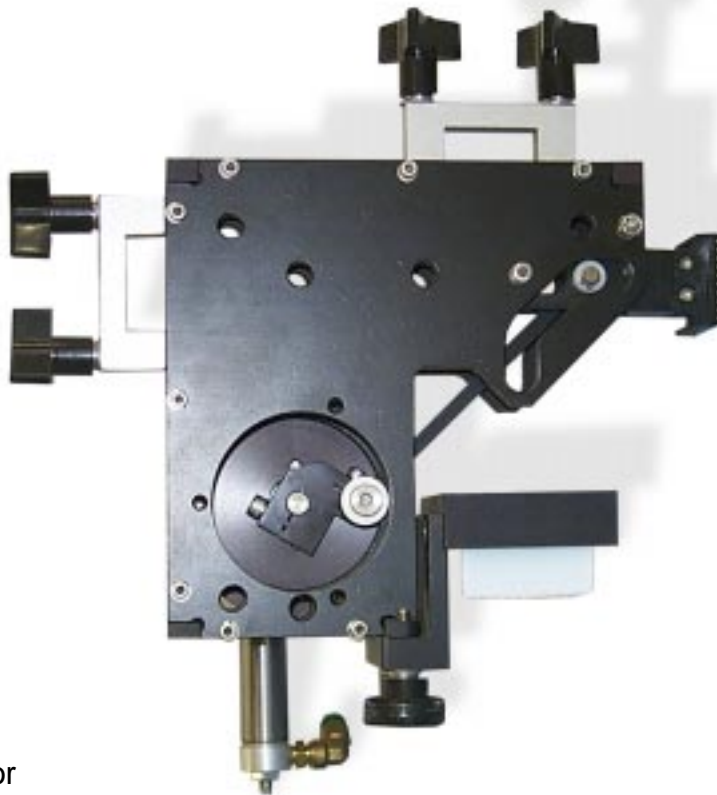

Designed for these Packaging Machines

- Vertical Form-Fill-Seal
- Wrappers
- Vacuum Packaging
- Horizontal Form-Fill-Seal
- Label Applicators
- Cartoners

Benefits

- No warm-up time
Reduces operating costs
- Inexpensive yet effective
alternative to metal or
brass type
- No mechanical or
electronic failure
- No direct tie into
packaging machine for
drive
- Range of fast dry inks for
high print quality at the
lowest cost per print
- Lengthens cartridge life
- Fits easily on ALL
packaging machines

BELL-MARK

331 Changebridge Road • Pine Brook, NJ 07058
<P> (973) 882-0202 <F> (973) 808-4616 <E> info@bell-mark.com

Specifications

- Print Area:** 1.25" x 1.25"
(31.75mm x 31.75mm)
2" x 2"
(50.8mm x 50.8mm)
- Printing Element:** Rubber type logos
- Printing Medium:** Bell-Mark disposable ink cartridge
- Drive:** Single - stroke rotary air cylinder
- Control:** Solid state AC relay and direct solenoid
- Signaling:** Micro, prox switch, electric eye or customer "Hot Signal" to auxiliary relay
- Electrical:** 115 V/50 - 60HZ / 1Ph
1 amp fuse
- Air:** 20-30 PSI non-lube systems
(approx. 0.016 scfm. cycle)
- Mounting:** Printer mounted on custom bracket
- Dimensions:** See Drawing
- Weight:** 5 lbs.
- Cycle rate:** Up to 180 cycles/min.
(depends on package length & line speed)
- Web speed:** Continuous up to 50 FPM

Supplies/Accessories

Rubber Type Systems:
Bell-Mark offers a complete range of adhesive back rubber type systems for the US-5000 including: date sheets, price logos, lot numbers and custom made logos for special applications.

Bell-Mark's high quality ribbed logos insure consistent printing.

Ink Cartridges

- Self-contained **and** disposable
- Consistent high quality impressions
- Speedy reloading - no downtime
- Prints on both absorbent and non-absorbent surfaces - dries in seconds
- Lasts up to **5** eight hour shifts
- Cartridge adaptable to all competitive ink coders

US5000 Dimensional Drawing

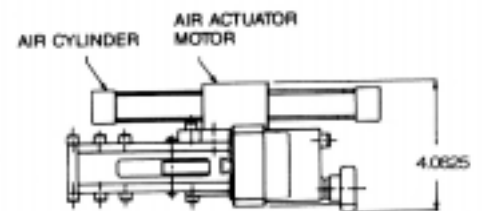
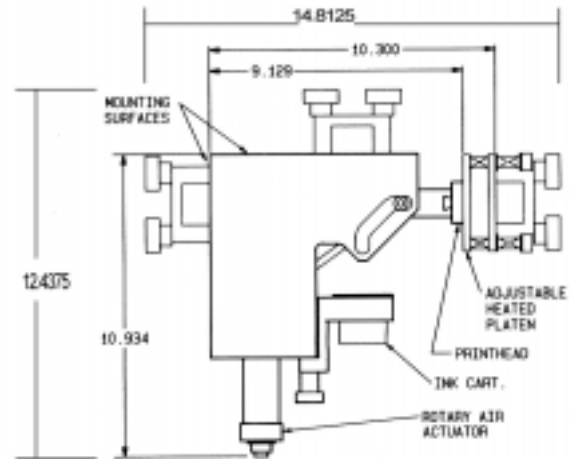

Vacuum Packaging Machine

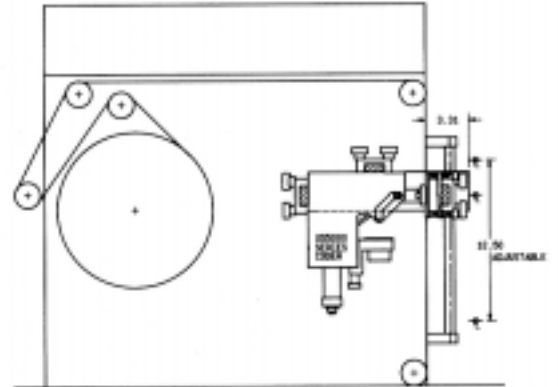

Wrapper

